



# HS-NH400 4-Port 10BaseT Ethernet Hub

## Installation Instructions

### Introduction

The HS-NH400 is a 4-Port 10BaseT IEEE 802.3 - compliant Ethernet Hub for use with the DSC Concourse Home Systems wiring solution. The HS-NH400 is a convenient way to interconnect up to four computers or computer peripherals such as printers and scanners in a residential or home office LAN at distances of up to 100 meters from the hub. This module can be installed in any of the Concourse Home Systems cabinets using the supplied mounting hardware.

### Contents of Package

Before installing the module, confirm that the package contains the following parts:

- one HS-NH400 Ethernet card
- one 9VDC 500mA power supply
- one HS-MP200 mounting plate
- four plastic standoffs.

**Caution:** *The HS-NH400 is a static-sensitive device. Handle with appropriate care.*

### Installation Instructions

1. Insert the standoffs into the mounting plate as per Figure A, matching the hole pattern on the HS-NH400 Ethernet Hub.

Figure A

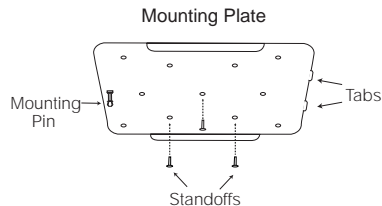

2. Align the HS-NH400 Ethernet Hub over the stand-offs and snap into place.
3. Locate a suitable mounting location for the HS-NH400 Ethernet Hub inside the cabinet.
4. Align the two mounting tabs with the holes in the wire raceway and insert as per Figure B.
5. Snap the module into place by pushing the opposite side towards the back of the cabinet.

Figure B

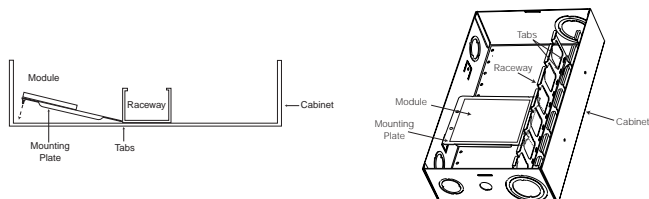

## Wiring Instructions

### **Option A: Using the HS-DH800 Data/Voice Distribution Hub (see Figure C)**

1. Home-run CAT5 cable to each desired location and route the cables into the cabinet through the raceway to an HS-DH800 Data/Voice Distribution Hub. Allow sufficient length at both ends of the run to avoid stress and for proper termination and trim out. Label each cable at both ends for easier identification.

**Note:** *Maximum total length of run from the hub to the networked device should not exceed 100 meters. We recommend keeping the cable run to 90 meters, allowing 10 meters for the patch cord from the wall jack to the device.*

2. Terminate each CAT5 data drop at the desired location using an RJ-45 keystone jack wired to TIA T568A standard, observing proper CAT5 wiring practices. Trim out using the appropriate wall plate. If using a multiple outlet mark the data jack accordingly.
3. Terminate each CAT5 data drop at the HS-DH800 Data/Voice Distribution Hub IDC termination blocks using a 110 punchdown tool and observing proper CAT5 wiring practices. Refer to the *Installation Instructions* included with the HS-DH800 for installation and connection instructions.
4. Test all connections to confirm proper termination.
5. Mate each CAT5 data drop on the HS-DH800 Data/Voice Distribution Hub to a port on the HS-NH400 Ethernet Hub using a CAT5 patch cord.
6. Locate a suitable 110V<sub>AC</sub> receptacle for placement of the power supply. If necessary, have a qualified electrician install a 110V<sub>AC</sub> receptacle close to the cabinet.
7. Route the output cord from the power supply into the cabinet and plug into the HS-NH400 Ethernet Hub 'PWR-IN' jack.
8. Apply power to the HS-NH400 Ethernet hub by inserting the power supply into the 110V<sub>AC</sub> receptacle.
9. Test network to confirm proper installation and termination.

**Note:** *A minimum of two and a maximum of four computers or peripherals must be connected for proper operation of the HS-NH400 Ethernet hub. The network connections can be made on any available port on the hub and are not restricted to specific ports. The computers and/or peripherals must be configured properly for peak performance of the hub. **Please consult the manuals supplied with your operating system software and your network interface cards for proper system configuration.***

**Important:** *All requirements for installation of CAT5 should be met for proper operation of connected equipment. Do not strip off cable sheathing more than required for proper termination. Do not kink or knot cable. Do not crush cable with cable ties. Do not bend cable at right angles or any other sharp bends. All cable bends should have a minimum 2" radius. Do not untwist pairs more than ½".*

### Option A. Using the HS-DH800 Data/Voice Distribution Hub

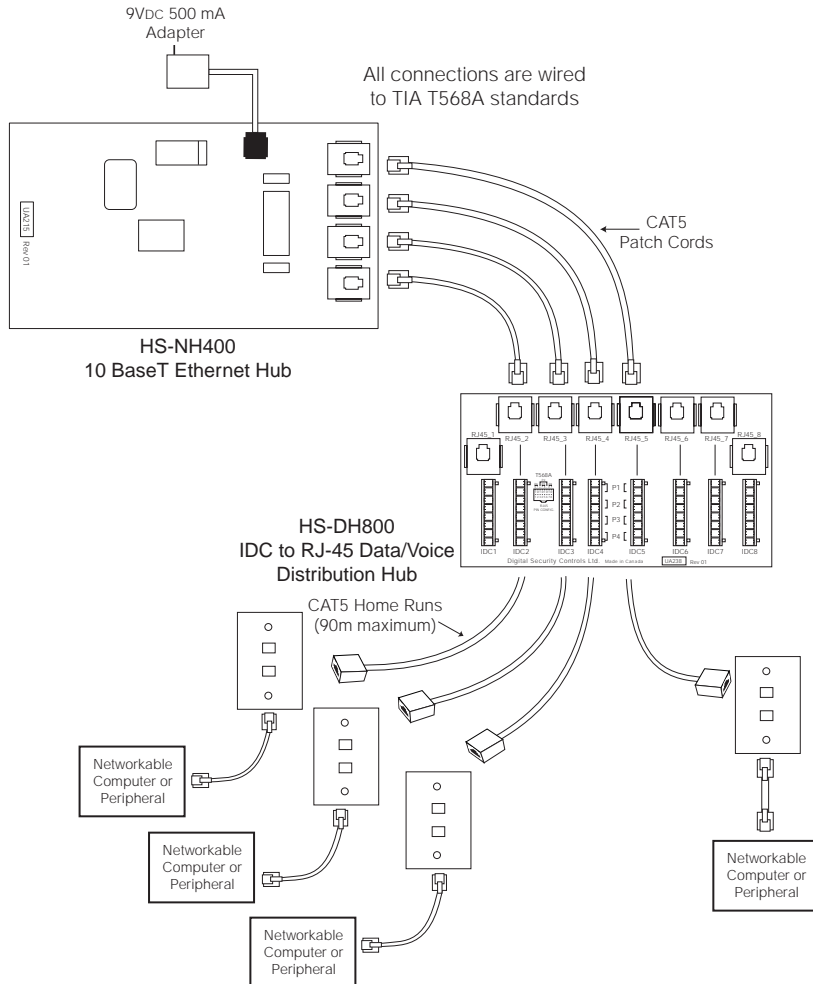

Figure C

### **Option B: Direct Wiring (see Figure D)**

1. Home run CAT5 cable to each desired location and route the cables into the cabinet through the raceway to the HS-NH400 Ethernet Hub. Allow sufficient length at both ends of the run for proper termination and trim out. Label each cable at both ends for easier identification.

**Note:** *Maximum total length of run from the hub to the networked device should not exceed 100 meters. We recommend keeping the cable run to 90 meters, allowing 10 meters for the patch cord from the wall jack to the device.*

2. Terminate each CAT5 data drop at the desired location using an RJ45 keystone jack wired to TIA T568A standard, observing proper CAT5 wiring practices. Trim out using the appropriate wall plate. If using a multiple wall outlet mark the data jack accordingly.
3. Terminate each CAT5 data drop at the HS-NH400 Ethernet Hub with an RJ-45 plug wired to TIA T568A standard, observing proper CAT5 wiring practices.
4. Test all connections to confirm proper termination.
5. Mate each CAT5 data drop to a port on the HS-NH400 Ethernet Hub.
6. Locate a suitable 110V<sub>AC</sub> receptacle for placement of the power supply. If necessary, have a qualified electrician install the 110V<sub>AC</sub> receptacle close to the panel.
7. Route the output cord from the power supply into the cabinet and plug into the HS-NH400 Ethernet Hub 'PWR-IN' jack.
8. Apply power to the HS-NH400 Ethernet Hub by inserting the power supply into the 110V<sub>AC</sub> receptacle.
9. Test network to confirm proper installation and termination.

**Note:** *A minimum of two and a maximum of four computers or peripherals must be connected for proper operation of the HS-NH400 Ethernet hub. The network connections can be made on any available port on the hub and are not restricted to specific ports. The computers and/or peripherals must be configured properly for peak performance of the hub. **Please consult the manuals supplied with your operating system software and your network interface cards for proper system configuration.***

**Important:** *All requirements for installation of CAT5 should be met for proper operation of connected equipment. Do not strip off cable sheathing more than required for proper termination. Do not kink or knot cable. Do not crush cable with cable ties. Do not bend cable at right angles or any other sharp bends. All cable bends should have a minimum 2" radius. Do not untwist pairs more than ½".*

## Option B. Using Direct Home Run Drops

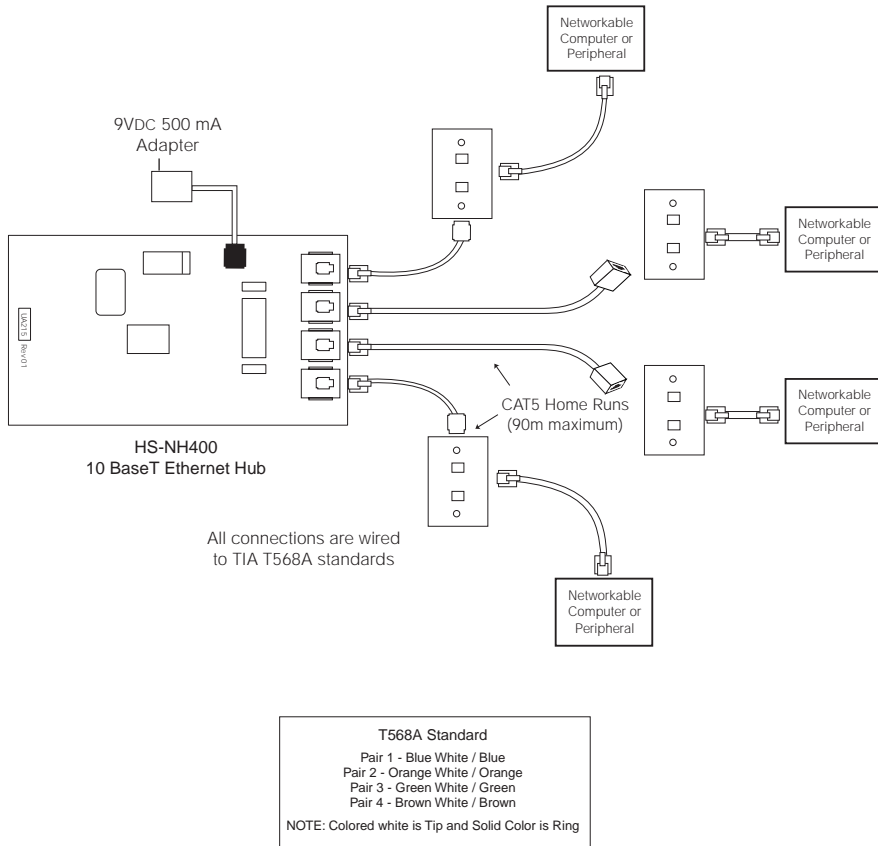

Figure D

## LED Color Guide

LABEL	COLOR	FUNCTION
Power	Red	Power Presence
CH-1	Green	Link Status
	Yellow	Collision Detect
CH-2	Green	Link Status
	Yellow	Collision Detect
CH-3	Green	Link Status
	Yellow	Collision Detect
CH-4	Green	Link Status
	Yellow	Collision Detect
Global Act	Red	Collision
	Yellow	Carrier Sense
Bandwidth Meter	Red	>80% Bandwidth Utilization
	Red	>64% Bandwidth Utilization
	Yellow	>32% Bandwidth Utilization
	Yellow	>16% Bandwidth Utilization
	Yellow	>8% Bandwidth Utilization
	Green	>4% Bandwidth Utilization
	Green	>2% Bandwidth Utilization
	Green	>1% Bandwidth Utilization

## HS-NH400 Specifications

The HS-NH400 4-Port Ethernet Hub is compliant with IEEE 802.3 specifications.

Standby current draw: ..... 96mA

Maximum current draw: ..... 330mA

Input voltage range: ..... 8 to 15V<sub>DC</sub>

Maximum Bandwidth: ..... 10MB/s

Dimensions: ..... 8.2 cm W x 14.5 cm L

## **FCC COMPLIANCE STATEMENT**

**CAUTION: Changes or modifications not expressly approved by Digital Security Controls Ltd. could void your authority to use this equipment.**

This equipment generates and uses radio frequency energy and if not installed and used properly, in strict accordance with the manufacturer's instructions, may cause interference to radio and television reception. It has been type tested and found to comply with the limits for Class B device in accordance with the specifications in Subpart "B" of Part 15 of FCC Rules, which are designed to provide reasonable protection against such interference in any residential installation. However, there is no guarantee that interference will not occur in a particular installation. If this equipment does cause interference to television or radio reception, which can be determined by turning the equipment off and on, the user is encouraged to try to correct the interference by one or more of the following measures:

- Re-orient the receiving antenna
- Relocate the alarm control with respect to the receiver
- Move the alarm control away from the receiver
- Connect the alarm control into a different outlet so that alarm control and receiver are on different circuits.

If necessary, the user should consult the dealer or an experienced radio/television technician for additional suggestions. The user may find the following booklet prepared by the FCC helpful: "How to Identify and Resolve Radio/Television Interference Problems". This booklet is available from the U.S. Government Printing Office, Washington, D.C. 20402, Stock # 004-000-00345-4.

## Warranty

Digital Security Controls Ltd. warrants that for a period of 12 months from the date of purchase, the product shall be free of defects in materials and workmanship under normal use and that in fulfillment of any breach of such warranty, Digital Security Controls Ltd. shall, at its option, repair or replace the defective equipment upon return of the equipment to its repair depot. This warranty applies only to defects in parts and workmanship and not to damage incurred in shipping or handling, or damage due to causes beyond the control of Digital Security Controls Ltd. such as lightning, excessive voltage, mechanical shock, water damage, or damage arising out of abuse, alteration or improper application of the equipment.

The foregoing warranty shall apply only to the original buyer, and is and shall be in lieu of any and all other warranties, whether expressed or implied and of all other obligations or liabilities on the part of Digital Security Controls Ltd. Digital Security Controls Ltd. neither assumes, nor authorizes any other person purporting to act on its behalf to modify or to change this warranty, nor to assume for it any other warranty or liability concerning this product.

In no event shall Digital Security Controls Ltd. be liable for any direct, indirect or consequential damages, loss of anticipated profits, loss of time or any other losses incurred by the buyer in connection with the purchase, installation or operation or failure of this product.

Motion detectors can only detect motion within the designated areas as shown in their respective installation instructions. They cannot discriminate between intruders and intended occupants. Motion detectors do not provide volumetric area protection. They have multiple beams of detection and motion can only be detected in unobstructed areas covered by these beams. They cannot detect motion which occurs behind walls, ceilings, floor, closed doors, glass partitions, glass doors or windows. Any type of tampering whether intentional or unintentional such as masking, painting, or spraying of any material on the lenses, mirrors, windows or any other part of the detection system will impair its proper operation.

Passive infrared motion detectors operate by sensing changes in temperature. However their effectiveness can be reduced when the ambient temperature rises near or above body temperature or if there are intentional or unintentional sources of heat in or near the detection area. Some of these heat sources could be heaters, radiators, stoves, barbecues, fireplaces, sunlight, steam vents, lighting and so on.

**WARNING: Digital Security Controls Ltd. recommends that the entire system be completely tested on a regular basis. However, despite frequent testing, and due to, but not limited to, criminal tampering or electrical disruption, it is possible for this product to fail to perform as expected.**

**IMPORTANT INFORMATION: Changes or modifications not expressly approved by Digital Security Controls Ltd. could void the user's authority to operate this equipment.**



---

©2000 Digital Security Controls Ltd.

Toronto, Canada

1-800-387-3630 • [www.dsc.com](http://www.dsc.com)

Printed in Canada 29005166 R001